

## DIGITAL PRESET TIMER - PROGRAMMABLE



Model Function	Timex 932	Timex 732	Timex 432
Size	(96 x 96 x 74) mm Refer Size (1) table	(72 x 72 x 74) mm Refer Size (2) table	(48 x 48 x 92) mm Refer Size (3) table
LED Display	3 Digit, 0.5" Height	3 Digit, 0.5" Height	3 Digit, 0.39" Height
Delay Mode	On delay , Off delay (interval) - Selectable.		
Time Range	9.99 , 99.9 , 999 Sec / 99.9 , 999 Min / 99.9 Hrs. - Selectable		
Start Input	Gate / Pulse start - Selectable		
Reset Input	Front panel key / Rear terminal for remote reset / At power on. ( Front panel reset key - enable / disable facility.)		
Relay Output	Two change over , with 5A @ 230VAC / 24 VDC contact ratings.		
Accuracy	0.05 % or 50 msec, whichever is greater.		
Power Supply	90 to 250 VAC/DC @ 50/60 Hz.( 24 VAC/DC provided on request)		
General Features	<b>Set Point : Single</b> set point , <b>Count Direction : Down</b> , Time Setting by key pad , Reset recovery time : < 100 msec Led indication for Relay status, Mounting : Panel mounting type		
Memory Retention	-----	10 year, available in Model: <b>Timex 732 MR</b>	10 year, available in Model: <b>Timex 432 MR</b>

## DIGITAL PRESET TIMER - PROGRAMMABLE DUAL DISPLAY



Model Function	Timex 962	Timex 762	Timex 462
Size	(96 x 96 x 74) mm Refer Size (1) table	(72 x 72 x 74) mm Refer Size (2) table	(48 x 48 x 92) mm Refer Size (3) table
LED Display	3+3 Digit, 0.5" Height	3+3 Digit, 0.5" Height	3+3 Digit, 0.39" Height
	3 Digit Process time + 3 Digit Set time		
Delay Mode	On delay, Off delay (interval), Cyclic on / off time first with single / multi cycle - Selectable.		
Time Range	9.99 , 99.9 , 999 Sec / 99.9 , 999 Min / 99.9 Hrs. - Selectable		
Start Input	Gate / Pulse start - Selectable		
Reset Input	Front panel key / Rear terminal for remote reset / At power on. ( Front panel reset key - enable / disable facility.)		
Relay Output	Two change over , with 5A @ 230VAC / 24 VDC contact ratings.		
Accuracy	0.05 % or 50 msec, whichever is greater.		
Power Supply	90 to 250 VAC/DC @ 50/60 Hz.( 24 VAC/DC provided on request)		
General Features	<b>Set Point : Single</b> set point , <b>Count Direction : UP</b> , Time Setting by key pad , Reset recovery time : < 100 msec Led indication for Relay status, Mounting : Panel mounting type		
Memory Retention	-----	10 year, available in Model: <b>Timex 762 MR</b>	10 year, available in Model: <b>Timex 462 MR</b>

# TIMING DIAGRAM

## TIMEX - 462 / 762 / 962

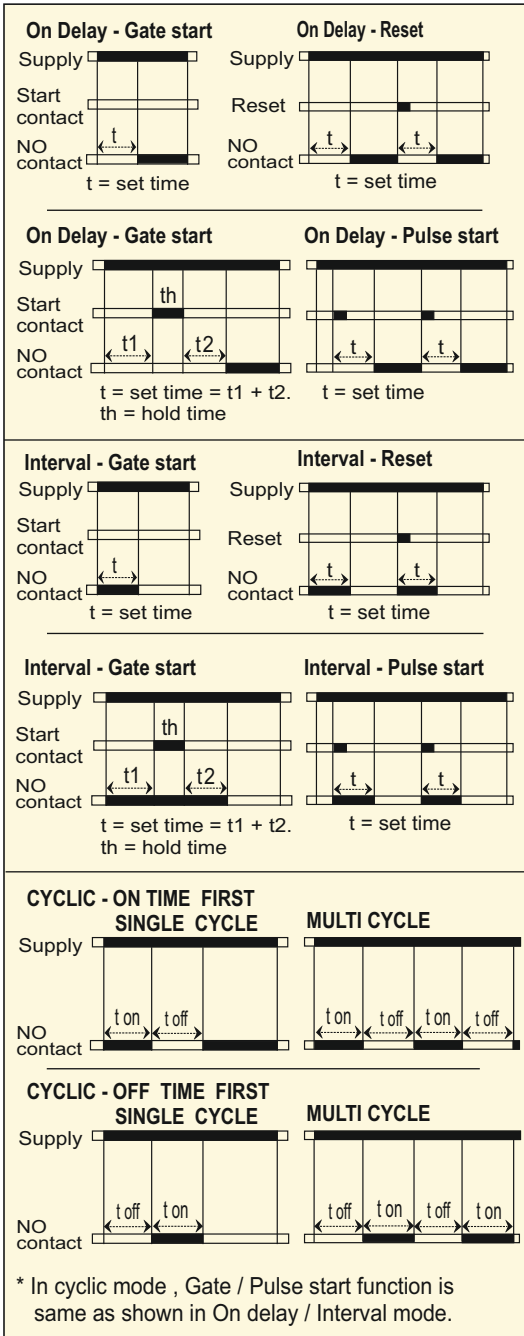

## TIMEX - 432 / 732 / 932

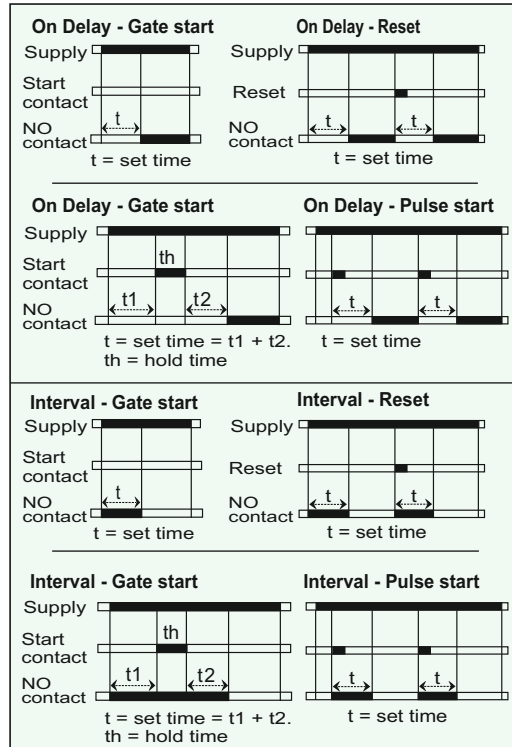

## OVER ALL MOUNTING DIMENSIONS (in mm)

DIM	SIZE					
	A	B	C	D	E	F
SIZE - (1)	96	96	74	10	92	92
SIZE - (2)	72	72	74	10	69	69
SIZE - (3)	48	48	92	4	46	46